



G-CAST®

MI KERB

MI precast concrete kerbs are manufactured with Grade 50 concrete under a Quality Management System complying to ISO 9001. Customized designs are available to suit project requirements based on individual customer requirements.

MI Kerb Without Opening (Weight : 63 kg)

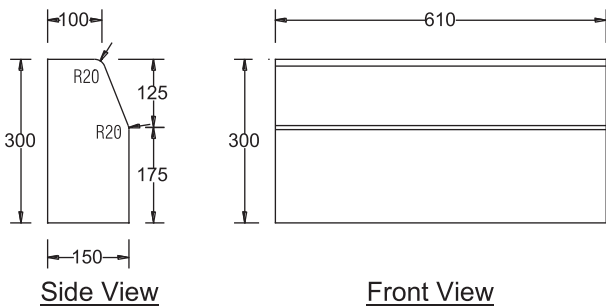

MI Kerb With Opening (Weight : 50 kg)

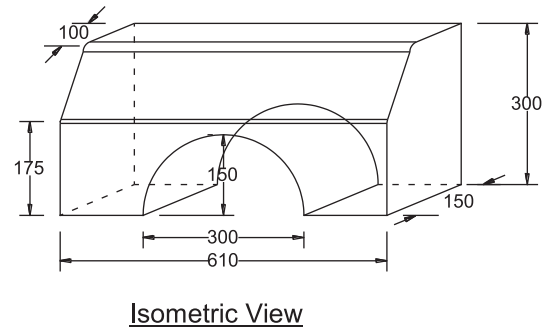
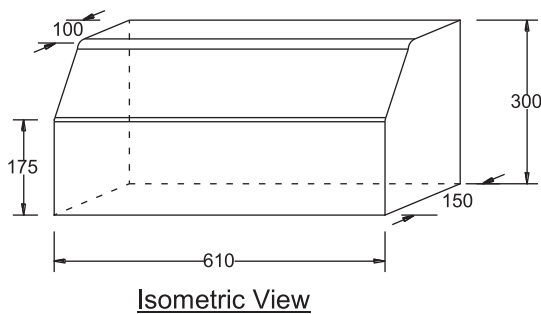
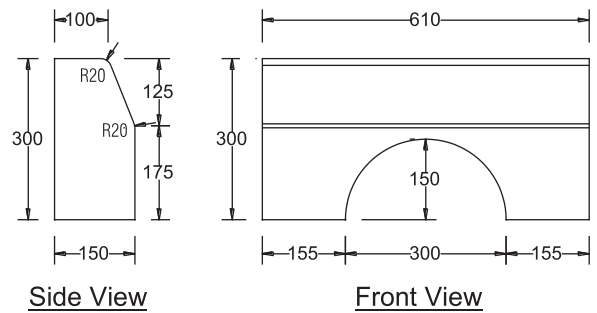

G-CAST CONCRETE SDN BHD (971228-X)

A-1-3A, Pusat Perdagangan Kuchai
No. 2, Jalan 1/127, Off Jalan Kuchai Lama
58200 Kuala Lumpur, Malaysia
T : +603 - 7982 8168
F : +603 - 7982 8068
www.g-cast.com.my

Factory:

- ☒ Plot 6, Jalan Bunga Azalea 1/2, Kawasan Industri Jalan Bunga Azalea, 48200 Serendah, Selangor
- ☒ Lot 647, Jalan Kulai Kota Tinggi, Mukim Ulu Sungai Johor Kota Tinggi, Johor
- ☒ Lot 12448-12473, Kawasan Perindustrian Bidor, Mukim Bidor, Daerah Batang Padang, 35500 Perak
- ☒ Lot 1561, Kampung Stesen, Sungai Choh, 48000 Rawang, Selangor